

(No Model.)

3 Sheets—Sheet 2.

G. T. WHITNEY. BORING MACHINE.

No. 535,747.

Patented Mar. 12, 1895.

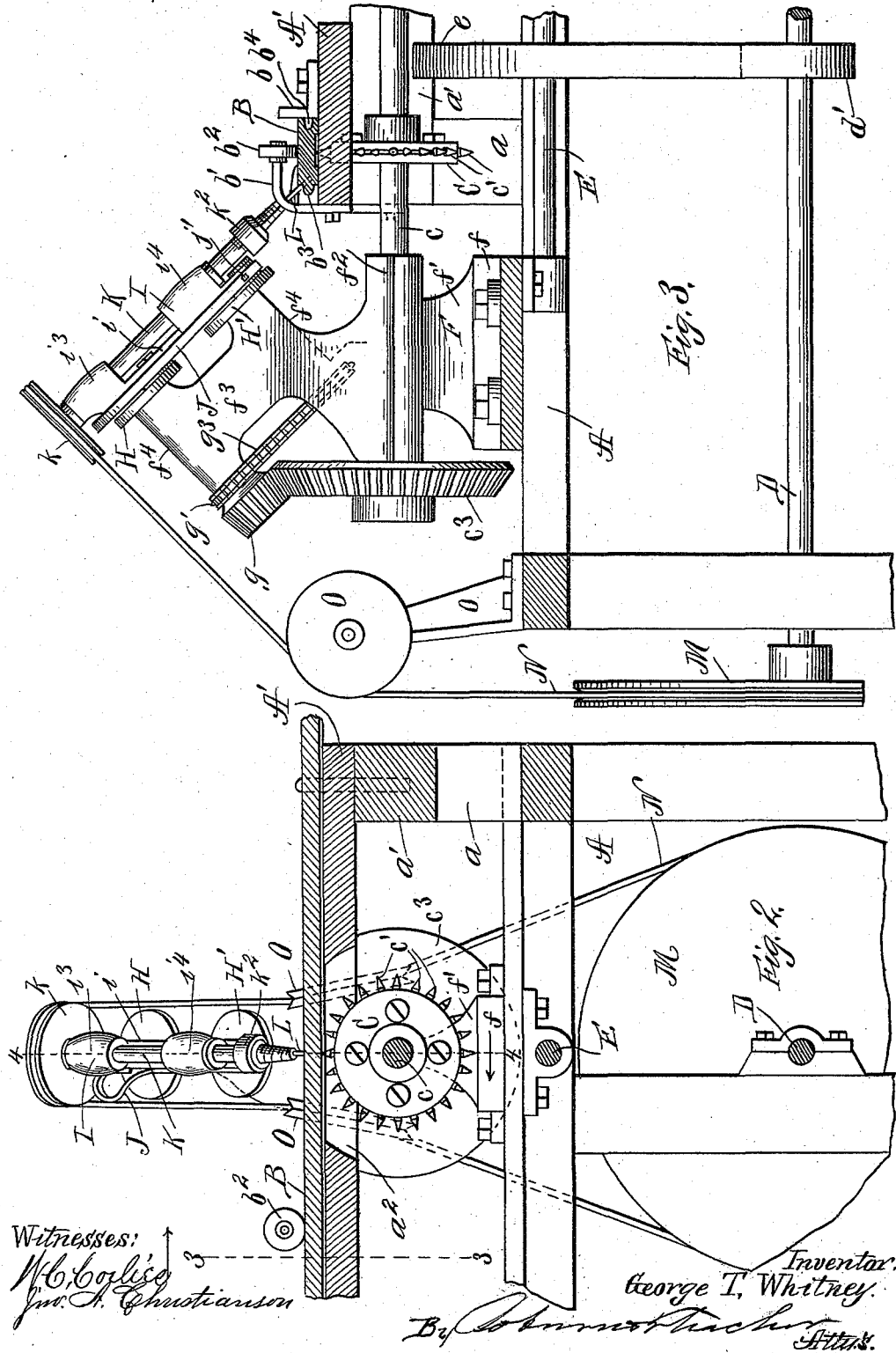

G. T. WHITNEY. BORING MACHINE.

No. 535,747.

Patented Mar. 12, 1895.

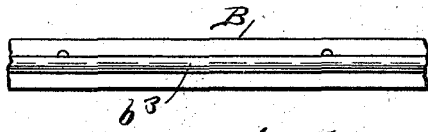
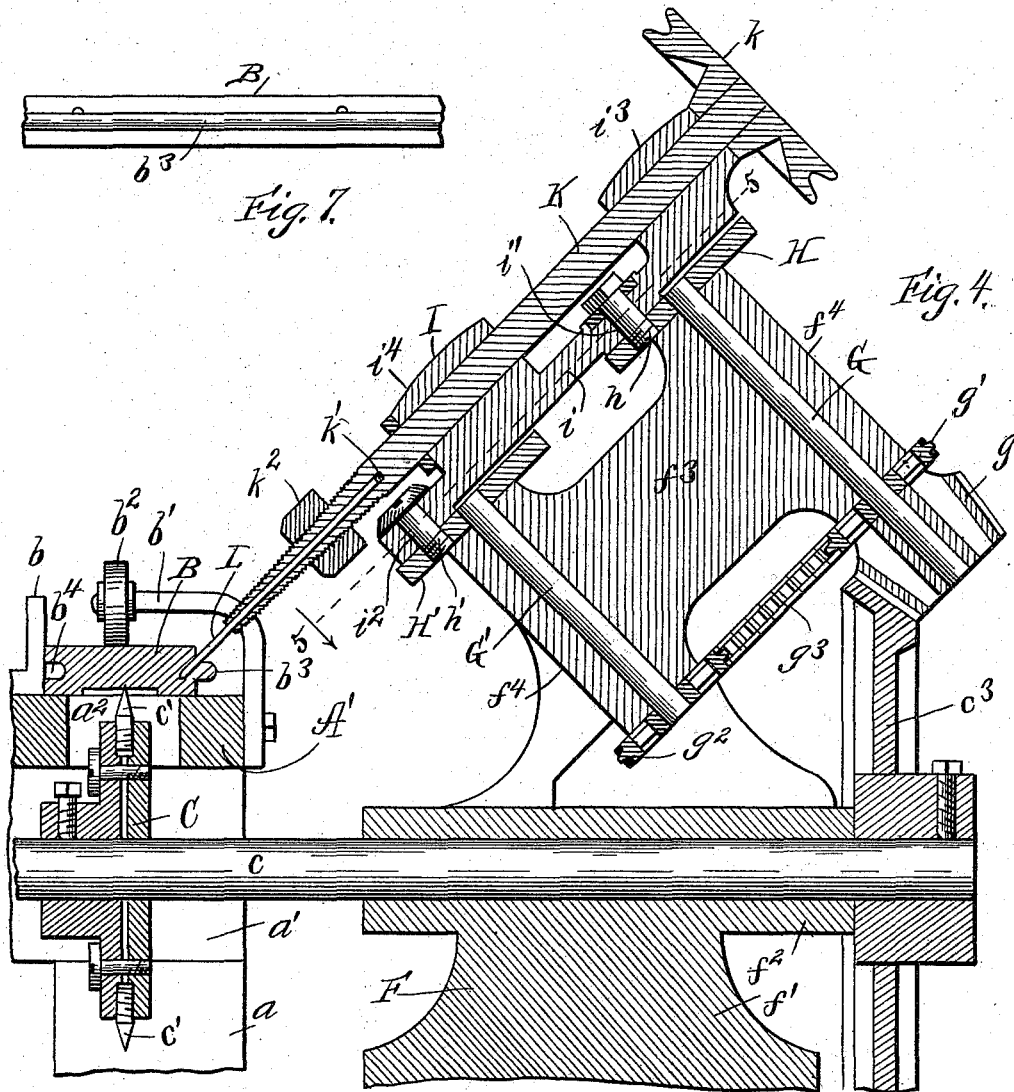

Fig. 7.

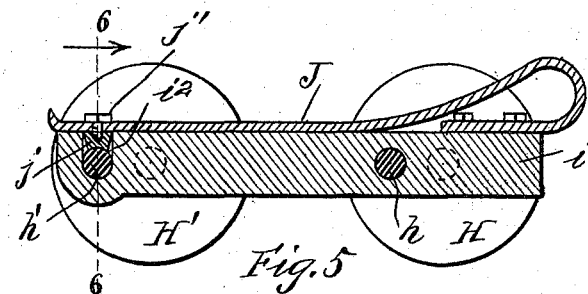

Fig. 5.

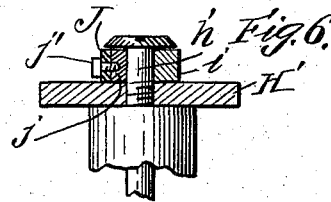

Fig. 6.

Witnesses:
W. C. Godley
Jno. A. Christianson.

Inventor:
George T. Whitney.
 By *Robert Thacher*
Attys.

UNITED STATES PATENT OFFICE.

GEORGE T. WHITNEY, OF CHICAGO, ILLINOIS, ASSIGNOR, BY DIRECT AND MESNE ASSIGNMENTS, TO AMOS L. WOOD, OF SAME PLACE, AND JUSTUS M. STEVENS, OF PRINCETON, ILLINOIS.

BORING-MACHINE.

SPECIFICATION forming part of Letters Patent No. 535,747, dated March 12, 1895.

Application filed June 19, 1894. Serial No. 515,023. (No model.)

To all whom it may concern:

Be it known that I, GEORGE T. WHITNEY, a citizen of the United States, residing at Chicago, in the county of Cook and State of Illinois, have invented certain new and useful Improvements in Boring-Machines, which are fully set forth in the following specification, reference being had to the accompanying drawings, in which—

10 Figure 1 represents a rear end elevation of a machine embodying my invention; Fig. 2, a detail section of the same taken on the line 2. 2 of Fig. 1; Fig. 3, a cross-section taken on the line 3. 3 of Fig. 2; Fig. 4, a similar section taken on the line 4. 4 of Fig. 2; Fig. 5, a detail plan section taken on the line 5. 5 of Fig. 4; Fig. 6, a detail section taken on the line 6. 6 of Fig. 5; and Fig. 7, a side elevation of a section of a floor board after the operation, showing the action of this machine. In these drawings Figs. 1, 2, and 3 are upon one scale; and Figs. 4 to 7 inclusive are upon another and enlarged scale.

My invention relates to machines adapted to bore holes part way into the edges of flooring strips for receiving the fastening nails for driving. I do not limit my invention, however, to machines for this special purpose, but contemplate its application to any boring machine requiring an operation similar to that which will be described herein. The flooring referred to above is of that type in which the strips are rather narrow, usually of hardwood, and are secured together by tongue and groove connection. These strips are secured to the joists by nails driven in at an angle over the tongue at one side of the strip, and in order to prevent the breaking of the tongue or spline, or splintering the edge of the strip by the driving of the nails, holes referred to above are bored a little way into the strip to receive the ends of the nails at first insertion without any forcible driving. The machine shown in the drawings is adapted to this purpose, though, as suggested above, my improvement may be applied to a machine designed for any other work of the same general nature.

In the drawings, A, represents the upright,

main frame of the machine, constructed for adaptation to the special work for which it is intended. At one side of this frame there is a raised table or bed, A', running along the length of the table and resting on suitable supports connected to or forming a part of the main frame, the posts, a, of the main frame at this side being extended above the top of the frame proper, and beams or sills, a', being provided for this purpose in the construction illustrated in the drawings. Near the rear end of the machine this bed is cut out partially to provide an opening, a², extending through it. This table is intended to receive the material in which the holes are to be bored. As seen in the drawings, the said material is a strip of flooring, B, the position of which on the table is determined by suitable gage-guides, b, secured to the table some distance outward from its inner edge and adjustable transversely thereof.

A bent arm, or arms, b', are fastened to the inner edge of the table extending upward therefrom and then bent outward, so as to provide a horizontal section directly over the table, on which a roller, b², is mounted, under which the strip of wood, B, is intended to pass and which rests upon the upper surface of this strip, so as to hold it firmly in position.

The strip, B, is shown constructed in the ordinary way with a tongue or spline, b³, along one edge and a corresponding groove, b⁴, in the opposite edge. If only one roller is used, it is located just in front of the opening in the bed so that it will hold the strip down at this point where the feeding device operates. This feeding device is a toothed wheel, C, fixed on a horizontal shaft, c, mounted in suitable bearings on the supporting frame and running transversely thereof just underneath the table and below the slot opening therein.

The feed-wheel is provided with sharp teeth, c', arranged radially around its periphery, and the diameter of this wheel is such that it will extend up into the slot opening, a², in the table sufficiently far to bring the points of these teeth into contact with the under side of the strip, so that by its revolution it will

feed the strip along, and this feed will be regular and uniform because of the long, sharp teeth.

Power is communicated to the shaft, *c*, to rotate it from a main shaft, *D*, mounted in suitable bearings near the lower part of the main frame and extending across the latter. At one end this shaft is shown provided with a driving pulley or gear, *d*, through which the shaft is rotated by the proper application of power from any suitable source. Above this main shaft is mounted a shorter shaft, *E*, parallel with the main shaft and provided with a fixed pulley, *e*, with which a pulley, *d'*, on the main shaft is belted, these pulleys being arranged between the sides of the frame. The shaft, *E*, also carries a fixed pulley, *e'*, which is belted with a pulley, *c*², on the shaft, *c*, this last set of pulleys being arranged outside of the pair of pulleys, *e*, *d'*, and obviously the feed-shaft, *c*, will thus be rotated from the main shaft.

A metal frame or standard, *F*, is mounted on the main frame at the side of the raised portion which carries the table and inside of the latter, as seen in Fig. 1. This frame is something like a large bracket standing upright on the main frame, to which it is secured by a suitable foot-plate, *f*, bolted to the main frame. It is located about opposite the toothed feed-wheel described above. From the foot the frame rises to form a substantially upright section, *f'*, in which is provided a horizontal bearing, *f*², for the end of the feed-shaft, *c*, which is extended considerably beyond the plane of the table. The upper part of this standard is a section, *f*³, standing at an angle to the upright section, being inclined backward and outward from the table, as seen in Fig. 1. The opposite ends of this inclined section are elongated somewhat, so as to project a little beyond the body, and they are set out a little to one side of the straight section, and are perforated so as to provide inclined bearings, *f*⁴. In the upper one of these bearings a shaft, *G*, is mounted, and in the lower one a similar shaft, *G'*, these shafts projecting a little beyond their bearings at each end. The shaft, *G*, projects most at its lower end, and is there provided with a bevel-pinion, *g*, fixed thereon. Just inside this pinion there is also fixed to this shaft a sprocket or chain-wheel, *g'*, and on the corresponding end of the shaft, *G'*, there is fixed a similar wheel, *g*². On the projecting end or extension of the feed-shaft, *c*, outside of its bearing, *f*², there is fixed a bevel gear-wheel, *c*³, which engages with the bevel-pinion, *g*, on the projecting lower end of the shaft, *G*. Obviously this provides for the driving of the shaft, *G*, from the feed-shaft, *c*. The sprocket-wheels on the respective shafts, *G*, *G'*, are of the same size, and over them is run an ordinary driving-chain, *g*³, so that the rotation of the shaft, *G*, mentioned above will communicate a similar rotation to the shaft, *G'*, and

both these shafts will rotate uniformly together.

On the upper end of the shaft, *G*, just outside its bearing, there is fixed a plain wheel or disk, *H*, and on the corresponding end of the shaft, *G'*, there is fixed a like wheel or disk, *H'*. The disk, *H*, is provided with a pin, *h*, arranged eccentrically to its shaft and projecting outwardly a slight distance from the disk. The disk, *H'*, is provided with a similar pin, *h'*, similarly arranged. These two pins are mounted at the same distance from the centers of the disks, so that their eccentricity to the centers of motion of the said disks is precisely the same and when the disks are rotated these eccentric pins will travel in the same circular path around the centers of motion of the said disks.

It will be understood from the above description that the rotation of the shafts, *G* and *G'*, described above, will communicate a corresponding rotary movement to the disks. A carrier for the shaft of the auger, drill, or borer of any kind, is mounted upon these rotary disks, the connection being through the eccentric pins just described. This carrier, *I*, as shown in the drawings, consists of a short, rather narrow, strip of metal, *i*, the upper end of which is provided with a simple aperture, *i'*, through which the pin, *h*, passes into the disk, *H*, and thereby journals the outer or upper end of the carrier to this disk. The lower end of the carrier may be connected to the disk, *H'*, in the same way, but for convenience I prefer a modification which permits the carrier to yield and be even disconnected from the disk at this end. For this purpose the aperture, *i*², for the pin, *h'*, is opened outward through one edge of the plate, so that it makes a kind of open notch or recess in the plate instead of a closed aperture, the opening being sufficiently wide to permit the pin to pass through it, so that this end of the plate may be slipped upon the pin underneath its head by simply swinging the plate in the proper direction.

Obviously some device is required to hold the lower end of the plate in proper position, however. In the drawings this device is a long, flat spring, *J*, fastened at one end to the upper end of the plate and thence bent over and passing down along the edge of this plate to the bearing recess and across the mouth of the same, as seen in Fig. 5. This end of the spring is free, and is provided with a slightly elastic plug, *j*, which is fastened to the inside of the spring by a screw-bolt, *j'*, or any other suitable device, and is located so as to be forced in through the bearing opening against the pin, *h'*, by the action of the spring, the tension of which is intended to have sufficient force to hold this movable bearing normally in against the pin, as seen in Fig. 5; but the lower end of the spring being free, it may be thrown outward by the hand, thereby removing the bearing block sufficiently far from its

seat to permit this lower end of the carrier plate to be swung out and so disconnected from the lower disk, thus making it convenient for the insertion or exchange of the auger or other boring device, as will presently appear, or for repairs as may be necessary. This spring also permits yielding to prevent breakage in case of obstruction.

In the embodiment of my invention in machines for practical use, the relative movement of the lumber feed and the borer carrier is intended to be such that the lateral movement of the carrier will correspond with the feed movement, at least from the moment when the bit comes in contact with the lumber to the moment it leaves the same upon retraction from the hole bored; that is to say, the lateral movement of the carrier from one of these points to the other will be made in substantially the same time as the feed of the lumber for the same distance, which may be determined by vertical lines or planes from each of said points to the feed; but the movement of the bit in its regular path will not thus correspond with the feed movement, for this path of the bit is in the arc of a circle while that of the feed is on a straight line. Obviously the actual movement of the bit in this arc must be somewhat more rapid than the regular feed movement in a straight line, this difference being sufficient to effect the lateral movement of the bit between the two points named in the same time as the feed movement over a space of the same length. This is a matter, however, purely of mathematical calculation, and such calculation need not be given here, for it will vary in different machines and will be perfectly understood by an experienced mechanic; but without some additional device the operation of the machine probably would not be satisfactory under all conditions. It would be difficult to secure perfect accuracy in these movements at all times. The condition of the lumber may be such that the feed will vary somewhat. For instance, the surface upon which the feed device acts may be uneven and there may be knot-holes along the line of the feed; and furthermore the lumber will not always be clear, but may be more or less knotty, and, if the bit should contact with a knot, it would not enter quickly and there would at once be a disturbance of the regular motion, which might result in injury to the borer or other parts of the mechanism. The connection of the lower end of the borer carrier with the eccentric pin on the lower disk, by means of an open side recess and the yielding retention of these parts in position by means of the spring, J, as described above, obviates all this difficulty. Whatever may be the cause of any irregularity in the respective lateral movements of the feed and the borer, any injury therefrom will be prevented by the yielding of the lower end of the borer, occasioned by the yielding of the corresponding end of its carrier on account of the elas-

tic connection described above, and therefore this device, or something effecting substantially the same result, is very desirable in a practical machine.

The carrier, I, has two lugs, i^3-i^4 , rising from the upper or outer surface of the plate, the former at the upper or outer end thereof and the latter near the lower end, but inside of the pin opening. Both of these lugs are perforated lengthwise to provide suitable journal bearings for a spindle or shaft, K, which is mounted therein, as seen in Fig. 4, and is provided at its outer or upper end, projecting a little beyond the upper bearing lug, with a hand pulley, k , fixed thereon, and as shown in the drawings, grooved. This shaft is a boring spindle, whatever boring or drilling device may be used, and at its lower end is constructed in any usual way to receive and secure a drill, L, which in this instance is intended to represent an ordinary auger-bit for boring holes in wood. The mode of fixing this bit in its shaft or spindle, shown in the drawings, consists in tapering and splitting the lower end of the spindle and providing an aperture, k' , adapted to receive the shank of the bit. A thread is cut upon the exterior of this section so as to provide a threaded tapering end, as seen in Fig. 4, to which is applied a suitable nut, k^2 , by means of which the split end is tightened upon the bit to hold it in place. The length of the bit and its shaft and the inclination thereof are designed to bring the end of the bit to the inner edge or side of the strip of flooring, just over the spline or rib thereon, in a proper position to bore a hole a little way into the strip, entering just above the spline and inclining downward, as indicated in Figs. 3 and 7.

Obviously the rotation of the shafts carrying the pin disks as described above will move the carrier in an eccentric path, by reason of its connection with the eccentric pins on the disks, the movement being precisely the same as though the connection between these two parts was by regular eccentrics and eccentric bands, and being the well known combination of lateral and lengthwise movement common to such eccentric drivers. It will also be noted that this movement of the carrier is positive and affects all parts thereof alike. There can be no deviation in the movement of the respective ends of the carrier. This mechanism then is a kind of adjusting device for the spindle, and as it is driven from the feed-shaft, obviously the movement of the carrier will bear a definite relation to the feed movement of the strip of flooring. The relation required is that one complete revolution of the disks will be made during the feed travel required to carry the strip the distance required between two nail holes, so that one complete movement of the spindle carrier will be effected during the feed travel of the said strip from one nail point to another. The relation of these two sets of devices is

also such that the end of the bit will be brought down to engage with the wood a little before the finish of the downward movement of the carrier. Then obviously the carrier will
 5 move downward sufficiently to bore the hole to the proper depth and at the same time will move laterally in a forward direction with the strip, the mechanism being so regulated that this lateral movement of the carrier will
 10 be perfectly uniform with the movement of the feed, and when the carrier reaches its lowest point, the hole will be sunk to its required depth, and immediately upon passing this point, the upward movement of the carrier will also commence and the bit will be
 15 withdrawn.

Evidently means must be provided for rotating the bit. The mechanism for this purpose shown in the drawings consists of a large
 20 band wheel, M, secured to the main shaft on the end opposite to the driving pulley and just outside of the main frame. As shown, this pulley is grooved to correspond with the pulley on the bit shaft. A suitable band, N,
 25 is run around these two pulleys, and as they are in different planes, guide pulleys, O, are mounted on a bracket, o, secured to the side of the main frame, these pulleys being also grooved to correspond with the main pulleys,
 30 and having their planes inclined downward and outward from each other on account of the different sizes of the driving pulleys, as seen in Figs. 1 and 2 of the drawings. These devices will, of course, impart the required
 35 rotary movement to the bit shaft and bit whenever the main shaft is revolved.

It is obvious from the description above that there is a forward feed imparted to the bit corresponding exactly with the forward
 40 feed of the floor strip, or other article which is to be acted upon, with a simultaneous lengthwise movement of the said bit, as required for the boring feed of the bit and its following retraction. It is to be noted also
 45 that the angle of presentation of the bit to its work is always the same, (normally,) because, as explained above, the attachment of the bit carrier to its moving parts is such that there can be no variation of this nature except
 50 under extraordinary conditions such as have been referred to above.

The proper relation of the movements of the several parts as described above is a matter of mathematical calculation, the basis of
 55 which is the required distance between the holes which it is desired to bore or drill in the articles or bodies which are to be operated upon. This distance will, of course, vary for different articles, and so no iron-clad rule of mathematical calculation can be here given.
 60 It will be perfectly well understood by any competent mechanic, so that the necessary calculations can be made properly for the adaptation of the machine to the special work
 65 for which it is designed.

Many modifications may be made in the

special devices which are herein described and shown, and such mechanical changes I contemplate without departing from the controlling features of my invention which have been
 70 above set forth, and as already suggested, the power for driving the machine may be derived from any suitable source whatever.

Having thus described my invention, what I claim to be new, and desire to secure by Letters Patent, is—

1. In a boring machine, mechanism for feeding the material to the borer, in combination with revoluble wheels or disks, a carrier mounted eccentrically upon said disks, a revoluble borer shaft mounted in bearings on said carrier, and mechanism for simultaneously
 80 rotating said disks in unison with the feed mechanism, whereby the borer is moved bodily both laterally and lengthwise in harmony with the feed movement of the material without changing the angle of presentation of the borer to the material during the operation of boring, substantially as described.

2. In a boring machine, two revoluble wheels or disks, H, in combination with a carrier, I, pivoted eccentrically to said disks at its respective ends, a revoluble borer shaft, K, mounted in suitable bearings on said carrier, mechanism for simultaneously and uniformly
 90 rotating said disks, and mechanism for rotating the borer shaft, substantially as described.

3. In a boring machine, a standard, F, having an inclined upper section, f^3 , the shafts, G, G', mounted in bearings at the respective
 100 ends of the said inclined section, wheels or disks, H, H', on the upper ends of said shafts, a carrier, I, pivoted to said disks at its respective ends eccentrically to their centers of motion, a borer shaft, K, mounted in journal
 105 bearings on said carrier, and mechanism whereby said shafts are rotated in unison, substantially as described.

4. In a boring machine, the revoluble wheels or disks, H, H', in combination with the carrier plate, I, provided at one end with edge recess or opening, v^2 , pins, h, h' , arranged eccentrically on the disks and connecting the respective ends of the carrier thereto, and a spring, J, provided with bearing plug, j , at its
 115 free end, adapted to enter the recess, v^2 , substantially as described.

5. In a boring machine, a support for the material, in combination with mechanism to feed the material to the borer, a suitable support at the side of the material support and inclined downward and outward therefrom, shafts, G, G', mounted in said support in a like inclined position, disks, H, H', fixed on the upper ends of said shafts and provided
 120 with eccentric pins, h, h' , a carrier, I, journaled at its respective ends on said pivot pins, a borer shaft mounted in bearings on said carrier, and mechanism connecting said inclined shafts with the feed shaft, substantially as described.
 125

6. In a boring machine, the inclined shafts,

G, G', in combination with wheels or disks, H, H', at their upper ends, carrier, I, eccentrically pivoted thereto at its respective ends, borer shaft, K, mounted in bearings on said carrier, driving mechanism connecting the shafts, G, G', with the feed shaft, main shaft, D, and driving band or belt, N, running over suitable pulleys on the main shaft and borer shaft, whereby the latter is rotated independently, substantially as described.

GEORGE T. WHITNEY.

Witnesses:

LE OTIE LEIB,

ALLAN A. MURRAY.